

---

## IMPLEMENTATION OF SMART STICK FOR BLIND PEOPLE

Prof. Dr. P. N. Yerkewar\*<sup>1</sup>, Diksha Vaidya\*<sup>2</sup>, Nikita Bandhekar\*<sup>3</sup>,

Ragini Jadhao\*<sup>4</sup>, Vaishnavi Nile\*<sup>5</sup>

\*<sup>1</sup>Guide, Priyadarshini Bhagwati College Of Engineering, Nagpur, India.

\*<sup>2,3,4,5</sup>UG Students, Priyadarshini Bhagwati College Of Engineering, Nagpur, India.

---

### ABSTRACT

Visually disabled people have to face many challenges in their daily life and problem gets worst when there is an obstacle in their way . People find difficulties detecting obstacles in front of them, during walking on the street, which makes it harmful ,so the stick is basically designed for blind people for easy navigation. In this project we propose a solution, we indicate clearly in a smart stick with ultrasonic sensor to detect stairs or pair of ultrasonic sensor to detect any other obstacles in front of the user, within a range of 1-1.5 meters. In addition , moisture sensor is placed at the middle of the stick for detecting water and puddles mostly in rainy season. When any obstacle is detected then buzzer beeps. This proposed system uses the microcontroller Arduino nano embedded system,buzzer,GSM,GPS,encoder IC, decoder IC,pcb. The stick is able to detect all obstacles in the range 10-15 meters during 39 ms . the visually impaired people can walk independently in unfamiliar environment .In this project we are going to use GSM module which is interfaced with GPS device therefore the care taker or relative receive the intimation message with location at their mobile phone in case of any emergency. The smart blind stick is of low cost, fast response, easy to design light weight.

**Keywords:** Ultrasonic Sensor, Water sensor, Visually impaired, Blind Navigation.

---

### I. INTRODUCTION

Many people suffering from serious visual impairments preventing them from traveling independently. Appropriately, they have to use a large vary of tools and techniques to need them in their travelling. One in all these techniques are orientation and quality specialist who helps the visually impaired and blind people and trains them to move on their own independently and safely counting on their different remaining senses.The originality of the proposed system is that it utilizes an embedded vision system of 3 straightforward Ultrasonic sensors and brings along all reflective signals in order to classify an obstacle through Arduino nano microcontroller. Hence, additionally to distance the proposed system allows the determination of main characteristics of the obstacle. To gather information about the obstacles presence in a road, three ultrasonic sensor can be used. In case of a passive sensor, the sensor receives a signal. Sensor detects the reflected, emitted or transmitted electro-magnetic radiation provided various natural energy sources.In order to using an active sensor, the sensor release a signal and receives a distorted version of the reflected signal. It finds reflected responses from objects radiated with artificially generated energy sources. These type of active sensors are capable of sensing and detecting far and near obstacles.Additionally, it determines an accurate measurement of the distance between the blind and the obstacle.Basically, in the obstacle detection domain, four different kinds of active sensors may be used: infrared, laser, ultrasonic, other than to radar sensors. Accordingly, training is then necessary to help the user understand the signals and to respond to them in real time. However, such training is occasionally more expensive than the product itself. Therefore, users can not afford it. Apart from that, the information is transmitted as a sound it may be embarrassing for the blind person in public.

**BLOCK DIAGRAM**

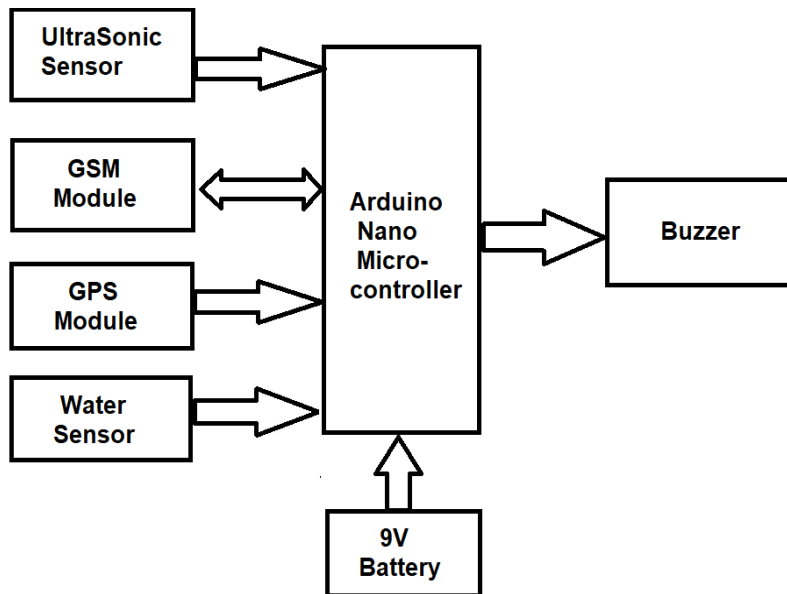

**Fig:** Block digram of Smart Stick

**BLOCK DIAGRAM DESCRIPTION**

**ARDUINO NANO:**

The Arduino Nano is a complete ,small and breadboard-friendly board based on the ATmega328 (Arduino Nano 3.x). Arduino nano has more or less the same functionality of the Arduino Duemilanove in a different package. It deficient only a DC power jack,andworks with a Mini-B USB cable instead of a standard one.

**GSM 800L MODULE:**

A GSM module or GSM modem is a hardware device that uses GSM mobile telephone technology to supply a data link to a remote network. From the perspective of the mobile phone network, they are necessarily identical to an or normal mobile phone, as well as the need for a SIM to identify themselves to the network.

**GPS MODULE:**

In the GPS system, heart of the module is a NEO-6M GPS chip from u-blox. The chip compute less than the size of a postage stamp but packs a surprising number of features into its little frame.It can track up to 22 satellites on 50 channels and reaches the industry’s highest level of sensitivity i.e. -161 dB tracking, whereas consuming only 45mA supply current.

**ULTRASONIC SENSOR:**

Ultrasonic sensor used sound waves to calculate how far away you are from object. Ultrasonic sensor supply more accurate and more reliable data.

**PCB:**

PCBs mechanically maintain electronic components using conductive pads in the shape designed to accept the component's terminals, and also electrically connect them using traces, planes and other features etched from number of sheet layers of copper laminated onto and/or between sheet layers of a non-conductive substrate. A printed circuit board (PCB) is a laminated combine structure of conductive and insulating layers.

**BUZZER:**

A beeper or buzzer is an audio signaling device which may be mechanical, electromechanical, or piezoelectric (piezo for short).

**LED:**

A light-emitting diode (LED) is a semiconductor light source that radiates light when current flows through it. Electrons in the semiconductor bring together with electron holes, releasing energy in the form of photons.

**HT 12E ENCODER IC :**

The HT12E is an encoder IC for RF and IR modules. This IC could be a 12-bit decoder that uses 8-bits for

address and four for information. The RF and IR modules will interface with microcontrollers instantly which needs comparatively complicated programming. moreover , this encoder IC straightforward} to style and simple to use. It comes in eighteen and twenty pins. each packages have solely eighteen purposeful pins.This encoder can use the logic states as information and address inputs. HT12E doesn't work alone.

#### **HT 12D DECODER IC :**

HT12D IC could be a CMOS series 12-bit RF decoder. largely remote applications have this technology. It gets to interface with the third device and helps it to decrypt 12-bits information. during this decoder, solely 4-bits area unit information the remaining half is that the address. The address can describe the placement however 4-bits combination may build sixteen forms of totally different combos. The HT12D decoder can't work alone. It works with associate other counterpart known as an encoder.

#### **WORKING PRINCIPLE**

This advanced smart blind stick using GPS and GSM module works on the principle of Ultrasonic sensors working which gives the drawbacks or information to microcontroller which is Arduino Nano in this case. Then microcontroller sends the message to care taker mobile phone or alerts the blind person what he has in front of him. Microcontroller Arduino nano is the main intelligent controller of this advanced smart blind stick and is programmed in embedded c language with the help of Arduino software. It is interfaced with GSM, GPS module, ultra-sonic sensor, and soil moisture sensor. 9v battery is used for providing the power supply to the smart blind stick. When examine this blind stick in normal condition then any object or obstacle is placed ahead of ultrasonic sensor then it gives the logic high signal to microcontroller, which also received the longitude and latitude of that particular object through GPS module. Hereafter, microcontroller gives the logic high signal to buzzer which is turned on.

When buzzer is on then blind person easily knows something is in front of stick or him. Similarly, during any critical condition when the blind person press the emergency switch then the microcontroller gives the logic high signal to GSM module as well as with the We have also used the soil moisture sensor for the condition when if there is water on the ground the sensor will sense the presence of water and it gives the logical high signal to the Arduino nano which will instruct the blind person about the presence of water.Later we have used 433Mhz RF transmitter and receiver to find the smart blind stick in case if it by mistake misplace. If the blind person forgets his stick somewhere and not able to find the stick then by using the RF transmitter switch, he can be able to establish communication with the stick. As soon as he presses the switch from the transmitter then at the receiver end the buzzer will make sound so that the blind person can find the stick.

#### **ADVANTAGES**

- It can prove to be a very low cost product.
- Since the system is linked with GPS and GSM module it provides direct information with the blend of latest technology and innovation.
- This system consist of different type of the sensor ,which is used to measure the distance and alert the blind people.
- Facilitates easier communication in case of an emergency.

#### **APPLICATION**

- The proposed system is an effective solution to millions of blind people worldwide.
- System enables the blind people to move with same ease and confidence as sighted people.
- Accident( if occurs ) , the spot can be detected easily and intimated to the caretaker of the blind person.

## **II. RESULT AND DISCUSSION**

This experiment results each hardware part. In this project we used ultrasonic sensor,GSM module,GPS module, Arduino nano.Arduino nano is main element in this circuit. The obstacles detected ny the the sensors and it gives that data to the microcontroller i.e Arduino nano.The GSM and GPS modules are interfaces with each other and connected to arduino nano.In case the stick is misplaced by the blind person , then the GPS send location through the interfaced module i.e GPS . Then the high voltage buzzer gets turn ON and the stick will found by the person.this In this manner the smart blind stick is work in this project.

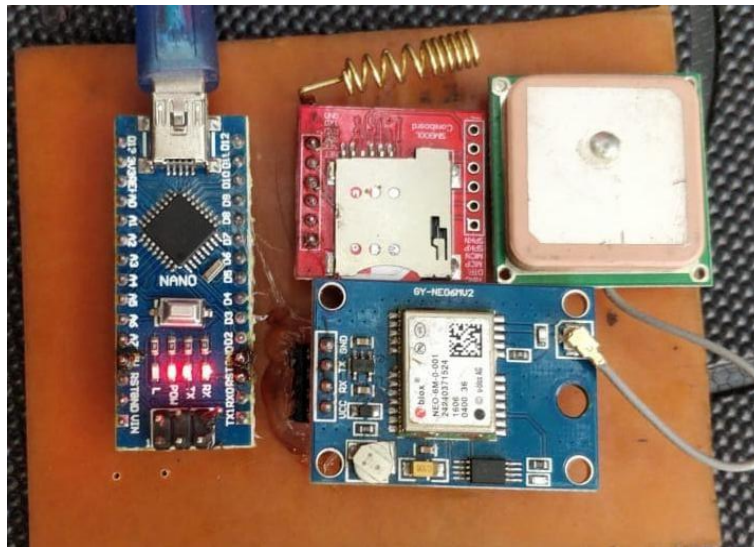

**Fig:** Snapshot of hardware of smart stick circuit

### III. CONCLUSION

This system provides a low-cost, reliable, portable, low-power consumption and powerful solutions for navigation with clear short response time. However, the system is essential with sensors, Arduino and other components. It is light in weight. Further feature of this system can be improved via wireless connectivity between the system components. Thus, increasing the range of the ultrasonic sensor and implementing a technology for determining the speed of detecting obstacles. At the time of developing such an privilege solution, visually disabled people and blind people in all fast developing countries were on top of our priorities.

### IV. REFERENCE

- [1] World Health Organization, "Visual Disability and Blindness," Fact Sheet N "282", Oct 2014.
- [2] Official Website of World Health Organization [www.who.com](http://www.who.com)
- [3] R. Radhika, P.G. Pai, S. Rakshitha and R. Srinath implementation of smart stick for obstacle detection and navigation.
- [4] Benjamin, J. M. Ali, N. A. Schepis, A. F.,1973,"A Laser Cane for the blind ."Proceedings of the San Diego Biomedical Symposium, vol. 12, pp.53-57.
- [5] S Romadhon, A K Husein,"Smart stick for blind using Arduino",International conference on science and technology 2019.