

## SURVEY PAPER ON AUTOMATION IN GREENHOUSE USING IOT

**Miss. Ovi Mali\*1, Miss. Sakshi Ostwal\*2, Miss. Akshada Shingavi\*3,  
Miss. Vaishnavi Rajhans\*4, Prof. Rohit Ghadage\*5**

\*1,2,3,4Student, Shri Chhatrapati Shivaji Maharaj College Of Engineering, India.

\*5Asst. Prof., Shri Chhatrapati Shivaji Maharaj College Of Engineering, India.

DOI : <https://www.doi.org/10.56726/IRJMETS63732>

### ABSTRACT

This work provides an IoT-based plant monitoring system for avoiding over-exploitation of resources, ensuring compact design with easy installation and the best environment for the plants to grow. This type of agriculture monitoring system provides environmental monitoring services that help the crop grow in good shape. The system offers the service of storing a database about the environment and soil information acquired from a wireless sensor network deployed in the planted area. Furthermore, it enables users to track environmental data regarding planted crop in real-time using any Internet-enabled device.

**Keywords:** Greenhouse, Iot, Internet-Enabled Device, Automation.

### I. INTRODUCTION

According to the United Nations' Food and Agriculture Organization, food production must increase with 60 percent to be able to feed the growing population. Modern farms can sprawl for hundreds of acres. Rising prices of fertilizer and electricity, combined with regulations limiting irrigation are placing increasing demands on farmers to more precisely utilize their resources. As the concept of the 'Internet of Things' becomes increasingly prevalent, many systems are being devised to allow all manner of data to be gathered and analysed, and devices controlled via wireless data networks. The crop agriculture in greenhouse is higher affected by the surrounding conditions. The significant environmental factors for the quality and better productivity of the plants growth are temperature, relative humidity, Lighting and moisture of soil in greenhouse. Continuous monitoring of these factors gives relevant information pertaining to the individual effects of the various factors towards obtaining maximum crop production.

### II. METHODOLOGY

The basic block diagram of IoT based greenhouse monitoring system using Arduino is shown in figure 1. The system is a greenhouse system in which there are four sensors. These sensors act as input to the micro controller system. The input feed provided to the micro controller is in the form of analog data. This data is converted by the controller into digital format. The data is shown on the LCD display and also on the android phone. Thus the monitoring of temperature, moisture and other parameters is done automatically. Once the parameter values are monitored they can be controlled by the embedded system.

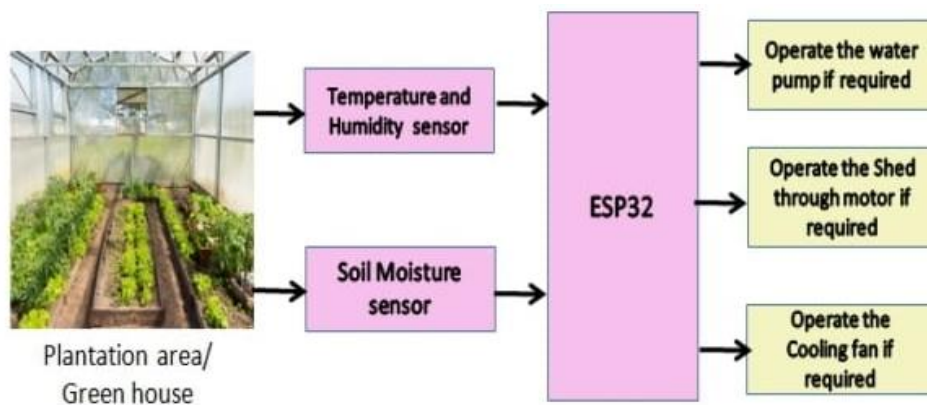

### III. MODELLING AND ANALYSIS

The Objective of the project is to develop a remote controlling and monitoring system for greenhouse applications. To understand the working principle of typical greenhouse control system and its main parameters. To provide an effective solution to the existence problem related to the greenhouse control system

technology by applying tools and techniques of problem solving. To apply tuning methods to the controller and analyze the results to come out with the best controller's configuration.

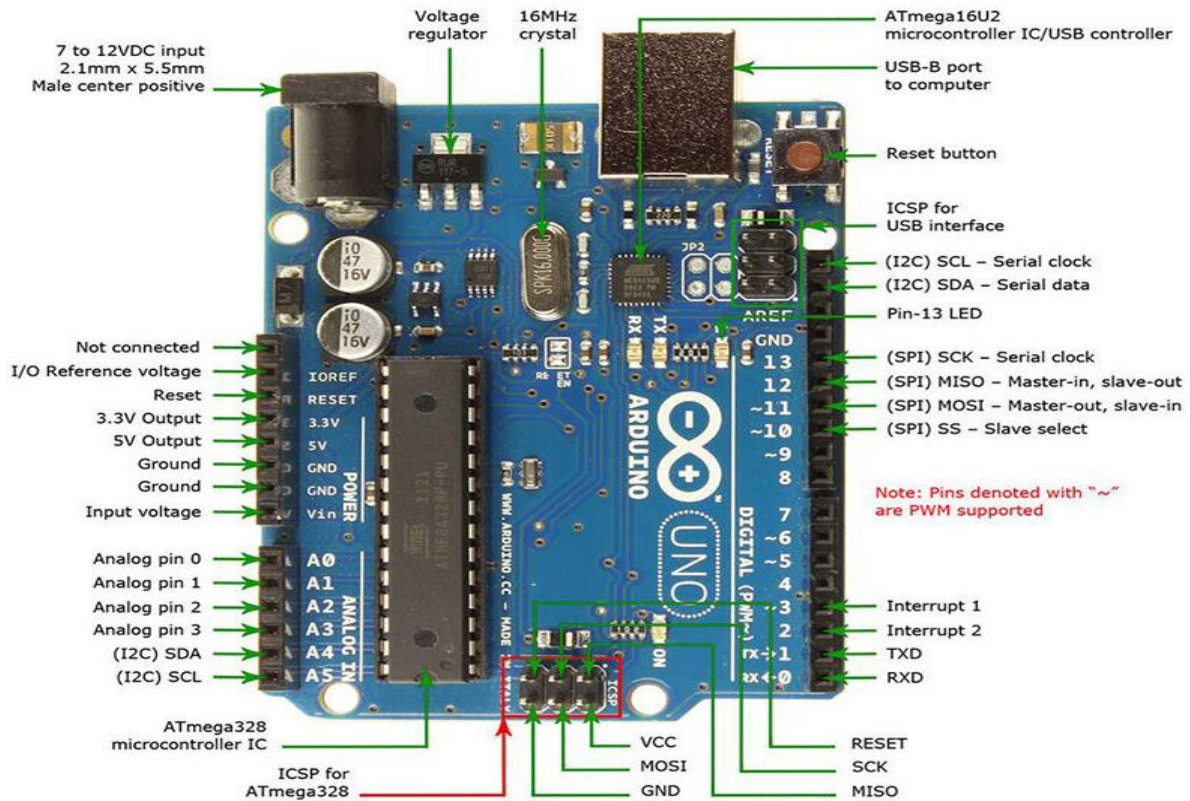

#### IV. SYSTEM ARCHITECTURE

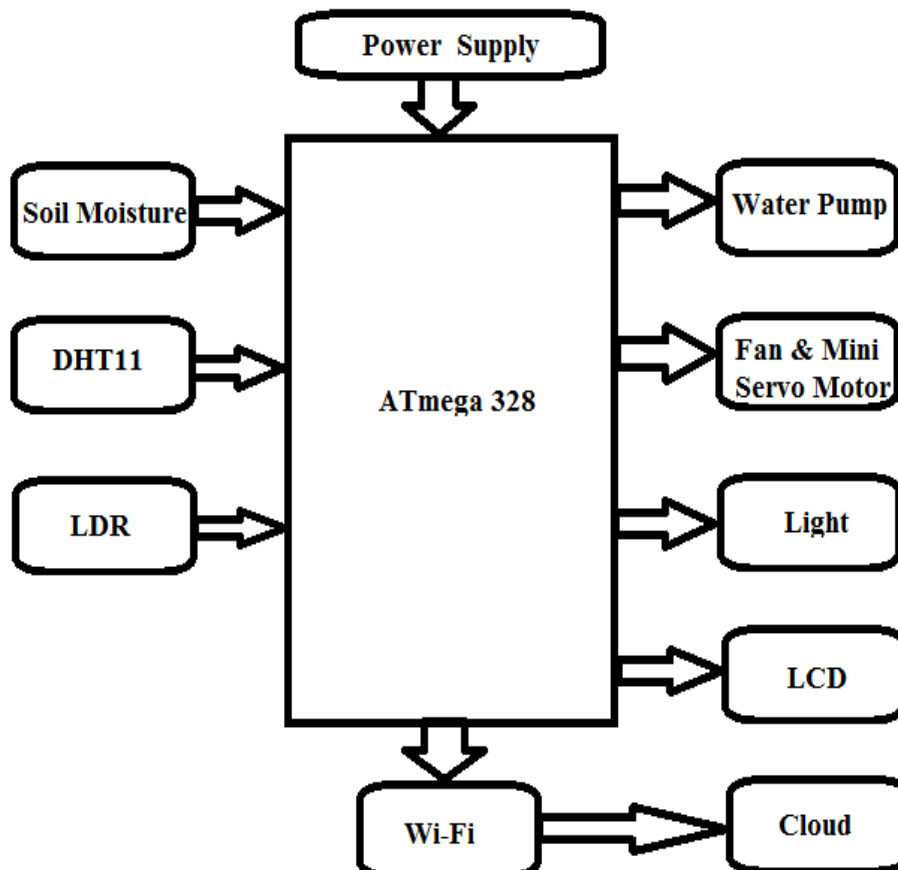

## V. CONCLUSION

The advantage of Smart Greenhouse over conventional farming is that we were able to produce Insecticide and pesticide free crops and create a climate for the proper growth of plants and even Provides alternative source of income through agriculture, selling tube well water etc. Moreover this system can be installed by any individual in his house (Rooftop greenhouse), who do not have Knowledge about farming. Since one can maintain any climatic condition in this type of Greenhouse, it is possible to cultivate any type of crop. Hence, we grow plants like Hibiscus which are imported to India. We can produce 70 percent to 80 percent water requirement. It also increases The yield and rate of growth and produces organic products. Most importantly, we are able to Connect farmer directly to consumer using IoT, which can save him from the clutches of Middlemen. It reduces effort and time if farmer and makes farming efficient and profitable activity. The smart greenhouse can be further upgraded in many ways and can be used in wide agricultural Applications. It can be placed and operated in any of the environmental conditions to grow any Kind of vegetation. Non-conventional energy sources such as solar panels, wind mills are used to supply power to the automatic greenhouse equipment and Peltier effect for cooling purpose. Soil- Less farming can be performed to further improve the nutritional value. Integration of farming with IoT can make it much more efficient and profitable activity. Smart Greenhouse has a bright scope Of future in agriculture field and it will create a revolution in the way the agriculture is carried out In India.

## VI. REFERENCES

- [1] "Automation in Greenhouse using IoT" by Ovi Mali, Sakshi Ostwal, Vaishnavi Rajhans, Akshada Shingavi, Prof.Rohit Ghadge (2024).
- [2] "Smart Plant Monitoring and Controlling System for Greenhouse Application using IoT" by Tejaswini Kar, Serhii Bilyk (2023).
- [3] Aditya Vishwakarma, Aniket Sahu, Nedeem Sheikh,Peeyoosh Payasi, Saurabh Rajput, Laxmi Srivastaava, "IoT Based Greenhouse Monitoring & Controlling System", IEEE, July10-12,2020
- [4] Pandu Naik, Sujana Sr, Amal Murali, Sagar Shetty, Sanjana Vasu , "Greenhouse Monitoring & Controlling Using IoT",IRJMETS, ISSN-2582- 5208, July 2021. 4. Junyan Ma, Kingshe Zhou, Shining Li, Zhigang Li (2022) , 'Connecting Agriculture to the Internet of Things through Sensor Networks2011 IEEE International Conferences on Internet of Things, and Cyber, Physical and Social Computing.
- [5] Shubham Borule, Shubham Ramteke, Mohit Tamgadge," Greenhouse Environment monitoring and controlling system,"IJSRT<ISSN No.2456-2165,Dec 2022
- [6] Shivnaresh Singh, Abhishek Kumar, Dinesh Singh, "Greenhouse Environmental Monitoring & controlling system,"IRJET,ISSN-2395-0056,May 2021
- [7] Pranshu Dubey, Manish Misha, Naman Bansal, Laksh Singhal, Khyati Kandpal, "IoT Based Greenhouse Environment Monitoring & Controlling using Arduino,"IJRES,ISSN-2320-9364,