

---

## WOMEN SAFETY CAB

**Dr. KM Prakash\*1, Manoj RS\*2, Ramesh M\*3, Megha Patri\*4, Latha M\*5**

\*1Associate Professor, Electronics & Communication Engineering Bapuji Institute Of Engineering And Technology, Davangere, India.

\*2,3,4,5Electronics & Communication Engineering Bapuji Institute Of Engineering And Technology, Davangere, India.

DOI : <https://www.doi.org/10.56726/IRJMETS45094>

---

### ABSTRACT

The Women safety cab project that aims to revolutionize the safety measures in transportation for women. This project incorporates advanced features that prioritize the security and well-being of female passengers. By integrating a combination of automatic locking mechanisms, emergency buttons, and real-time location sharing, this project ensures prompt assistance during potential threats or emergencies. The primary objective of Women safety cab is to create a safe and secure environment for women traveling alone or in groups. The project features an emergency button strategically placed within reach of the passenger. In the event of an emergency When Passenger feels trouble with Driver, pressing this button activates a series of actions. Furthermore, Women safety cab incorporates a kill switch feature for enhanced safety. If the passenger feels uncomfortable of driving the cab or changes the route then pressing this button activates kill switch instantly turns off the cab's engine. Additionally, the present location is promptly transmitted to the guardian or predefined numbers, ensuring that immediate help can be dispatched if required. To ensure comprehensive safety, Women safety cab employs real-time location sharing throughout the journey. This feature enables passengers and their guardians to track the cab's exact location and monitor the progress of the trip. This transparency promotes a sense of security and enables quick response in case of any deviations or concerns.

**Keywords:** Node MCU, GPS Technology, Women Safety, Android Application.

---

### I. INTRODUCTION

In recent years, there has been an increasing concern for the safety of women, especially while travelling. Women, in particular, have to face a lot of challenges and risks when they travel alone or at night. This has led to a need for solutions to ensure their safety and prevent any unfortunate incidents from happening. To address this concern, a Women Safety Cab Project has been developed which has a feature of locking the seatbelt and door lock of the driver in an emergency situation along with sending the location to the passenger guardian and police. One of the key features of the Women Safety Cab Project is the locking of the seatbelt and door lock of the driver in an emergency situation. This feature ensures that the driver cannot open the door or unfasten the seatbelt, preventing any potential harm to the passenger. The locking mechanism is triggered by an emergency button, which can be pressed by the passenger in case of an emergency. Another important feature of the Women Safety Cab Project is the location tracking system. The system is designed to track the location of the cab in real-time and send it to the passenger's guardian and the police in case of an emergency. The location tracking system ensures that the passenger's whereabouts are known at all times, and immediate action can be taken in case of any emergency.

### II. LITERATURE SURVEY

In the system presented in paper Likhitha K.N[1] incorporated SOS button. When this button is pressed, an SMS with precise location information is delivered to the currently selected cellphone number. When the victim asks for assistance, this information might be utilized to find her. Additionally, the device has a flashable LED that the assault victim may use to signal for help. When flashed from a suitable distance, this LED may temporarily blind the attacker for around five seconds. The victim now has a window of opportunity to flee. Women are protected and have flexibility under this arrangement. Shivani A Deshkar[2] In this paper A wide range of tracking systems has been developed so far tracking vehicles and displaying their position on a map, but none of the applications has been developed so far which tracks the mobility of a human being. Nowadays tracking a person's mobility has become a crucial issue these days, system that is cost effective and can be used for

tracking a human being using a GPS and GPRS equipped mobile phone rather than using a handheld GPS receiver. “The main focus of our project is to reduce the overall cost of tracking based on GPS system which is a satellite-based service which is available 24X7 everywhere in the whole world. GPS system can be used to get location, which includes details like latitude, longitude and altitude values along with the timestamp details etc. The paper Anjali Vainetha Akuskar[3] focuses on a security system created specifically to give women protection so they won't ever feel powerless in the face of such societal issues. The device looks like a regular pair of gloves and, when triggered, uses the Global Positioning device (GPS) to track the victim's whereabouts and the Global System for Mobile communication (GSM) to transmit emergency messages to three contacts and the police control center. The device includes a shrieking alarm that utilizes a real-time clock to summon assistance and it can also deliver an electric shock to the assailant in self-defense. Author: The gadget described in the paper Purushottam R. Hantode[4] has a mechanism that assures two notifications in the event that a woman becomes anxious or believes she is in peril. If a lady merely suspects she could be in difficulty, she can activate this mechanism. If a woman gets struck on the head from behind while using a button-press alerting system, she might not have time to press the panic button and no one would be made aware that she was in danger. In order to solve this issue, a lady should switch on the gadget while she is moving down a lonely road, a dark trail, or any other distant region. The only person who is authorized to use the gadgets is a woman. In the paper R. Sriranjini[5], a gadget that functions more like a safety system is presented. This gadget may be installed in a garment (like a women's blazer). It is a portable gadget with a lot of features and capabilities. The emergency push button is fastened to a jacket button. This device's primary function is to inform the women's parents and the police of their whereabouts. The victim's present location is tracked using a GPS system, and the message is sent to the pre-specified numbers using a GSM modem.

### III. OBJECTIVES

The main objective is:

- To provide an alert and safety system for women at real time by Sending the Message to Guardian and police with present Location.
- To provide a Real time security by Locking the Driver seat belt and Door.
- To provide an Android application, which has the feature of sending Present Location to Guardian and Police and also having Emergency button integrated on it.

### IV. METHODOLOGY

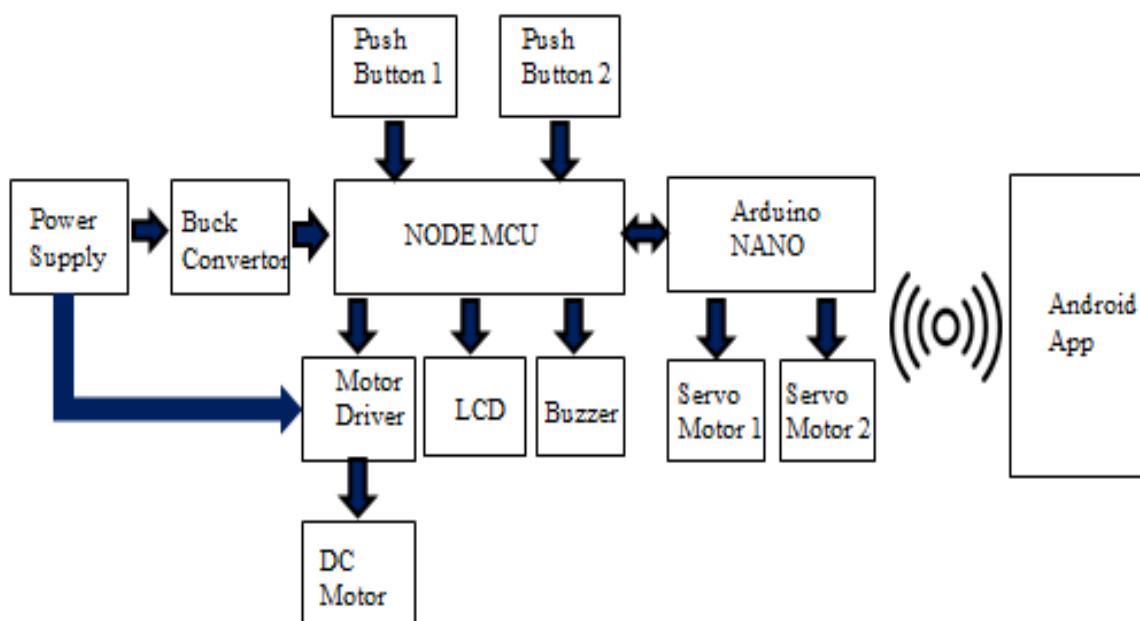

This system provides an alert and safety system for women at real time. This system contains an integrated Emergency button. When the user activates the Emergency button, The Driver's seat belt and Door will be locked and an SMS is sent to Women guardian and Cab Company/ Police with accurate location data. This data

is used to track down the Driver when she reaches out for help. In Addition to this, it has a feature of Emergency Engine kill switch button, when a passenger feels uncomfortable of driving the cab or changes the route In order to ensure their safety, the passenger can press the kill switch button it activates the mechanism to turn off the engine of the cab. As soon as the kill switch is activated, it sends a signal to the engine to turn off, bringing the cab to a stop. Once the engine is turned off, a message is automatically sent to the passenger's guardian and police officials. The message includes the current location of the cab, which helps in tracing the cab in case of emergency.

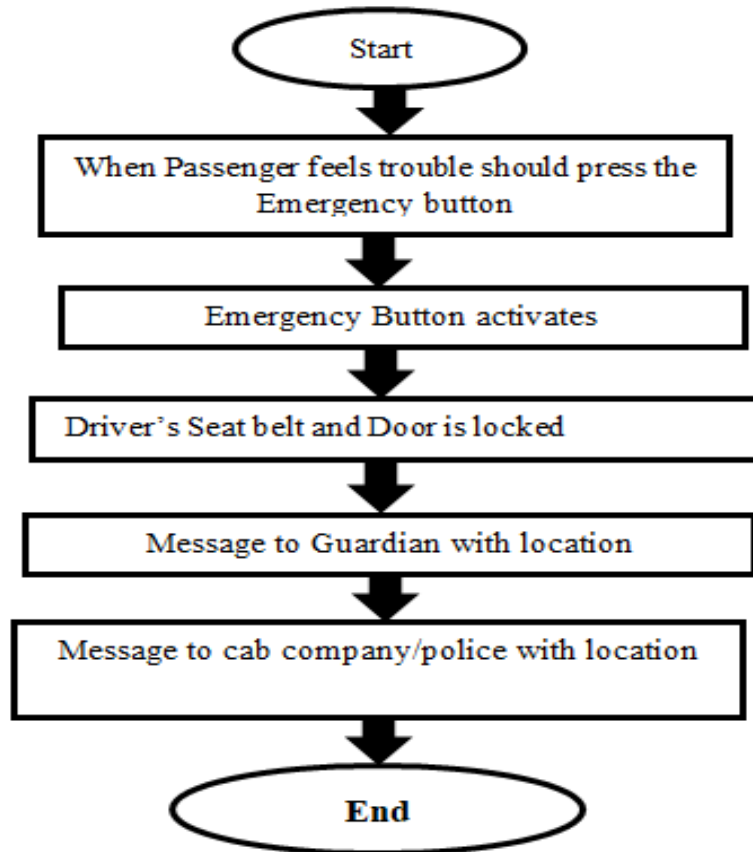

**Case1:** When Passenger feels trouble with Driver

**Start:** The process begins when the passenger boards the cab and starts the journey. Passenger feels trouble with driver: During the ride, if the passenger feels unsafe or uncomfortable with the driver's behaviour, she can press the emergency button.

**Emergency button activates:** The emergency button sends a signal to the microcontroller, which is programmed to respond to the signal.

**Driver's seat belt and door is locked:** Upon receiving the signal, the microcontroller sends a command to the motor driver, which activates the locking mechanism on the driver's seat belt and door of the cab. This action ensures that the driver cannot escape and take any harmful action towards the passenger.

**Message to guardian and police with location:** The microcontroller then sends an alert message to the passenger's designated guardian or emergency contact, along with the cab's location information obtained from GPS. It also alerts the local police department to take necessary action.

**End:** The process ends successfully, ensuring the safety of the passenger

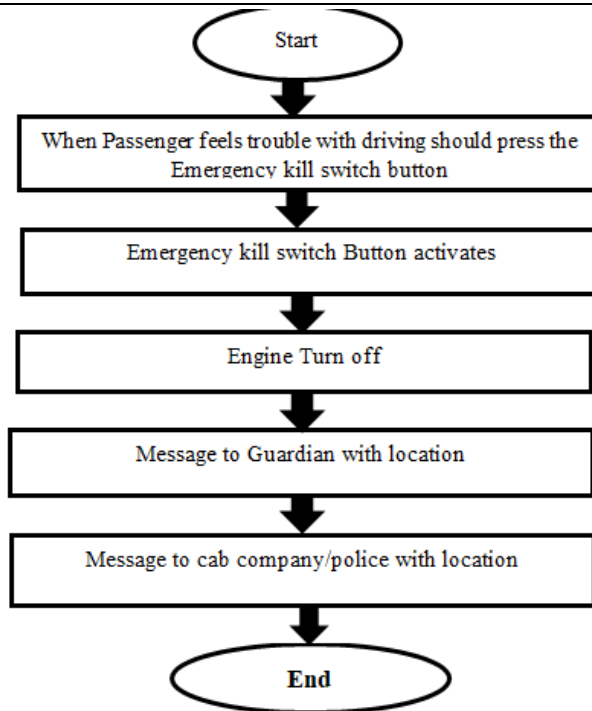

**Case 2: When Driver intentionally changes the Route or Rash Driving**

Start: The process begins when a passenger feels uncomfortable of driving the cab or changes the route.

Passenger presses the Kill Switch button: In order to ensure their safety, the passenger can press the kill switch button which is located in a visible and easily accessible place inside the cab.

Kill switch button activates: Once the passenger presses the kill switch button, it activates the mechanism to turn off the engine of the cab.

Engine is turned off: As soon as the kill switch is activated, it sends a signal to the engine to turn off, bringing the cab to a stop.

Message to guardian and police with location: Once the engine is turned off, a message is automatically sent to the passenger's guardian and police officials. The message includes the current location of the cab, which helps in tracing the cab in case of emergency.

End: The process ends successfully, ensuring the safety of the passenger .

**V. RESULTS AND DISCUSSION**

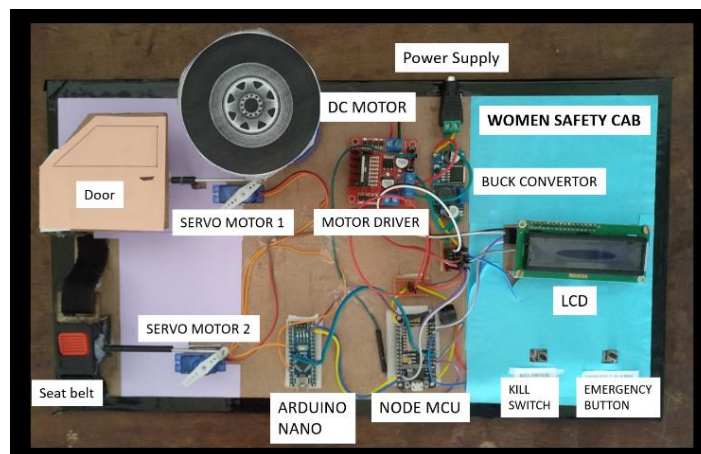

**Case 3: When Passenger feels trouble with Driver**

- From Power supply 12 Volt is given to the buck converter (DC-DC Converter), it converts 12 Volt to 5 volts which is required for all the components.

- And 12v is directly connected to Motor driver to run the DC motor. Initially when power is ON it initiates the system, ESP8266 Node MCU is connected to Wi-Fi network.
- Then the DC motor starts rotating which stands for Vehicle movement.

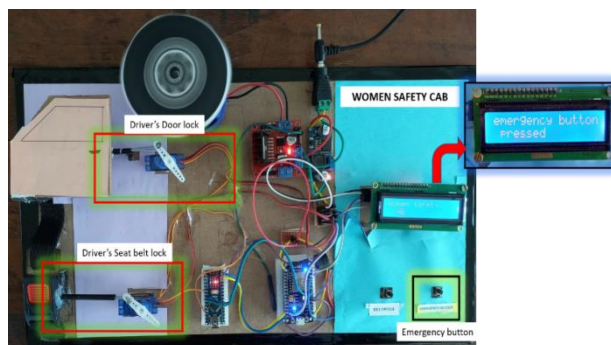

**Case 4:** When Driver intentionally changes the Route and Rash Driving.

If Emergency button is pressed by Women passenger the Servo motor is rotates 90 degree which locks the Driver's seat belt and door of Driver.



**Case 5:**

- If Kill switch is pressed the DC motor stops to rotate which resembles vehicle engine off.
- If they want to disable the Kill switch action passenger needs to press Kill switch again to disable the action which results in rotation of DC motor.

## VI. CONCLUSION

The Women Safety Cab project, which has a feature of locking seatbelt and door lock of the driver in emergency situations along with sending location to passenger guardian and police, is an important step towards ensuring the safety of female passengers during their journeys. By providing a reliable safety mechanism, this project can help prevent crime, provide peace of mind, and increase trust between female passengers and taxi services. Overall, the Women Safety Cab project has the potential to make a significant impact on the safety of female passengers, not just in taxis but also in other forms of public and private transportation. It is a step towards building a safer and more inclusive society where everyone can feel secure and protected during their journey.

## VII. REFERENCES

- [1] K.N. Likhitha, "Women Safety Device using GPS and GSM Modem" International Journal of Innovative Science and Research Technology ,Volume 4, 2019.
- [2] Shivani A Deshkar, Shraddha M Laxane, Payal MLendhare, Poonam N Khade, Prof. Ketki Shendhre, "Women security using Android App" , International Journal of Research Publication and Reviews, Volume 2, 2021.
- [3] Anjali Vaijnath Akuskar, Jyoti Subhash Jadhav, Poonam Sudhakar Kabade , "Women Security System" , IJCRT Volume 6, 2018.
- [4] Purushottam R. Hantode<sup>1</sup>, Govardhan S Sambhare<sup>1</sup>, Akash S. Golde<sup>1</sup>, Reeta G. Ingle<sup>1</sup>, Prof. Amit P. Joshi, "Women safety device with GPS tracking and alerts" , JSRSET, volume 4, 2018.
- [5] Sriranjini R, "GPS and GSM Based Self Defence System for Women Safety" , Journal of Electrical & Electronic Systems, 2017.