

SELF CHARGEABLE E-BICYCLE USING DYNAMO

Dr. Venu Murali Jagannati*¹, C. Abilash*², S. Yuvraj Reddy*³, L. Dinesh*⁴,
P. Dilli Prasad*⁵, R. Hemasai*⁶

*¹Associate Professor, Mechanical Engineering, Annamacharya Institute Of Technology & Sciences
(Autonomous), Tirupati, A.P, India

*^{2,3,4,5,6}Students, Mechanical Engineering, Annamacharya Institute Of Technology & Sciences(Autonomous),
Tirupati, A.P, India

DOI : <https://www.doi.org/10.56726/IRJMETS35713>

ABSTRACT

One of the greatest and most urgent needs of this world is to develop technology in the transport industry that can help to reduce the fossil fuel consumption exponentially. Our world is facing the danger of over exploitation of fossil fuels which in turns contributing a lot of pollution and global warming. Thus, working on a solution to reduce pollution and global warming, Electric bicycle is the perfect solution to reduce the causes. In E bicycle we use Lead acid battery, it is fast being recognized as a sustainable battery option because of its superior performance and life cycle. Therefore, lead acid battery based electric bikes can be major breakthrough in the transport industry. In the present work, we focus to enhance battery life while running, the Dynamo used in this setup to recycle the power for production and consumption simultaneously.

Keywords: Battery, Dynamo, Self-charging, Controller, E-Bike, Battery capacity.

I. INTRODUCTION

To get survival in planet, energy is most important. Hence there is in need of converting one mode of energy or additional alternative source of energy to fulfill our desires. Alternative energy sources include fossil fuels. We use many forms of energy generation, vehicle transportation, and so on. However, the disadvantage of the fossil fuels is unfriendly to the environment. To address the difficulties with fossil fuels, we must consider non-conventional energy sources. E-Bicycles energy requirements are influenced by a number of issues that will have an impact. E-bicycles energy consumption the vehicle's energy requirements are met by the distance, total weight, and distance. To address this issue, it was attempted throughout the report to carefully evaluate the system in order to ensure that the conclusions obtained in the end will be appropriate for a real instance. For example, the system's application of the system Petroleum fuel is used in all automotive two-wheeler engines. Other sources of energy are required to operate the vehicle due to the demand for fuel and the expense of fuel. As a result, we are turning to new sources of energy, such as electric power The self-charging E-Bicycle is a self-chargeable electric cycle that charges itself while running using dynamo. The dynamo is a device that generates electric power.

II. LITERATURE SURVEY

[1] In 2004, David and Sheng-Chung , proposed new parallel-type hybrid-electric-power system comprises an engine's energy distribution and a torque-integrated mechanism (specifically including an engine, a motor/alternator, a CVT device, and PCM as well as a 3- helical gear set).

[2] In 2005, Wenguang et al., presented an approach to control power train of series hybrid electric vehicles. A formulation of the system equations and controller design procedure were proposed by them. They also proposed a new switching algorithm for the power converter for motor torque and motor flux control.

[3] In 2007, Daniel designed, developed and implemented a series hybrid electric vehicle. Though he proposed the architecture as hybrid electric vehicle architecture, he showed that the vehicle runs well in the electric mode and left the hybrid conversion as future expansion.

[4] In 2012, Ian Vince Mcloughlin et al., were inventing the electric bicycle for the campus mobility in which they inculcated brushless DC motor which is mounted on either front or rear wheels for producing electricity. They also come with a modern technology that they provided navigation facilities for each system for the campus

they invented for with android touchscreen. This is because bikes require 200-250 watts of sustained pedalling force. So, most people don't accept it.

[5] In 2013, Minas Roukas et al., work on Development of the control system for an electric vehicle as a platform to construct EDV as a demonstration Vehicle & for testing modern technologies. It also provides control allocation for control system by providing desired speed & reduce oscillation. They also performed various simulation test for required trajectory for movement of vehicle.

[6] In 2014, Vivek V Kumar et al., worked on design & implementation of electric assisted bicycle with self-recharging mechanism. For this, a PMDC motor, flywheel, housing, multi- 15 DEPARTMENT OF MECHANICAL ENGINEERING crank freewheel, sprocket, battery and control system were used. The motor uses an effective discharge of 12V and 14A from the battery. However, it was found that the current drops to 1 as the effective speed increases.077 A.

III. EXISTING METHOD

1. In existing system One of the main problems with Self Chargeable E-Bicycle is limited Mileage.
2. Maintenance period was very low.
3. There is no On-Boarding Self Charging System. i.e., Dynamo

IV. PROPOSED METHOD

1. The dynamo arranged in a bicycle will generate electricity when the vehicle is in running condition.
2. In general, the bicycle starts by the rotary movement of the free wheel, which is in contact with the chain.
3. The dynamo, which is connected to the rear part of the bicycle near the rear wheel to generate electricity.
4. Electricity generated by the dynamo as above said process is stored in a lead acid battery, which is further will be used to the Hub motor connected at the front part of the bicycle over the front wheel.
5. Here, the Hub motor gives movement to the bicycle and helps to continue running. The electricity generated by the dynamo, the consumption of electricity by the Hub motor occurred simultaneously, thereby the life of the battery also enhances slightly when compared with bicycle without dynamo.

BLOCK DIAGRAM:

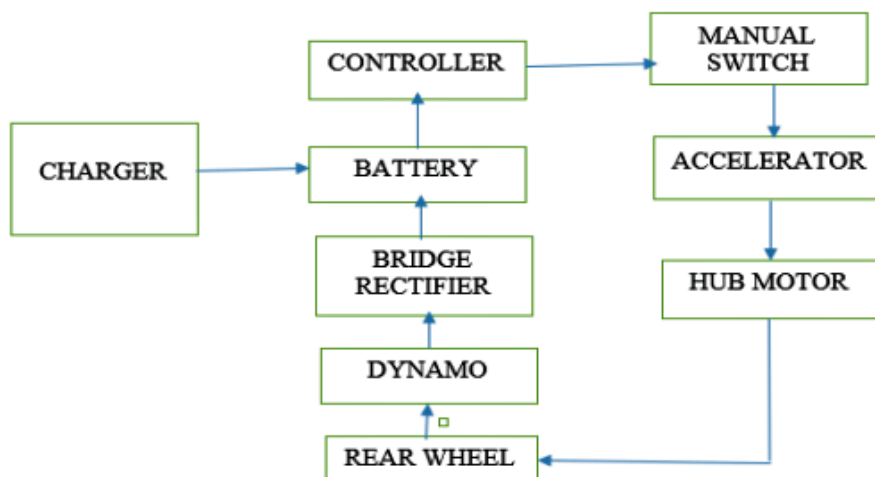

Fig - 1 Block Diagram

V. COMPONENTS

A. BICYCLE- Bicycle, also called bike, two-wheeled steerable machine that is pedaled by the rider's feet. On a standard bicycle the wheels are mounted in-line in a metal frame, with the front wheel held in a rotatable fork. The rider sits on a saddle and steers by leaning and turning handlebars that are attached to the fork.

B. BATTERY- The Lead-acid battery is one of the oldest types of rechargeable batteries. These batteries were invented in the year 1859 by the French physicist Gaston Plante. Despite having a small energy-to-volume ratio and a very low energy-to-weight ratio, its ability to supply high surge contents reveals that the cells have a

relatively large power-to-weight. Lead-acid batteries can be classified as secondary batteries. The chemical reactions that occur in secondary cells are reversible. Batteries = 3 (12v each).

C. CONTROLLER-The controller's main function is to take inputs from all the E-bike parts like throttle, battery, speed sensor, display, motor, etc., and determine what to be returned signal. The controller design has multiple protections that are: Low-voltage Protection, Over-voltage Protection, Over-temperature Protection, Over-current Protection, Brake Protection. Controller used in this project is 24 volts.

D. HUB MOTOR- 1. A hub drive motor is the most common type of motor you'll see on cheaper E-bikes, with the motor integrated into the front or rear wheel. The later is more common, but a few e-bikes even have motors on both wheels.

2. A hub drive directly applies torque to the wheel, operating independently of your bike's gears. e-bike hub motor, that can't run on DC directly, it needs a controller. The controller takes the DC and converts it into a variable frequency 3 phase AC. Hub motor used in this project is 36 volts.

F. DYNAMOIN - this project the dynamo act as a power generator from the rotation of rear wheel while it is running, because the rear wheel and dynamo are coupled due to friction between threads provided on both dynamo wheel and rear Tyre thread. The amount of power generated in the dynamo by the revolutions made by rear wheel is supplied to the rechargeable battery. The range of dynamo is 12v.

G. BRIDGE RECTIFIER -We can define bridge rectifiers as a type of full-wave rectifier that uses four or more diodes in a bridge circuit configuration to efficiently convert alternating (AC) current to a direct (DC) current.

H. THROTTLE AND LCD DISPLAY- The throttle mode on an electric bike is similar to a motorcycle or electric scooter, as when it is engaged the motor provides power and propels the bike forward. It gives you full power on demand with no automatic pedal assistance involved.

2. LCD battery display to know the remaining amount of electricity. You can recharge your e-bike on time, and it also display the speed of the E-bike.

I. LED Head Light and BUILT-IN Horn- 1. LED Head lights are used in low light conditions or after dark for better visibility of user.

2. Horns provide warning signals which are generated by an electric circuit

VI. OVERVIEW OF THE COMPLETE PROJECT



Fig 2: Prototype of self chargeable E-Bicycle using Dynamo

VII. RESULTS AND DISCUSSIONS

The Components which are Procured individually and they are arranged in a systematic way to the E-Bicycle and each part it is performing its function and we are getting good output that dynamo meter which is connected to the rear wheel of a bicycle it is integrated to the rechargeable battery, when the rear wheel is making revolutions for some distance simultaneously the dynamo meter which is coupled to the rear wheel is rotating and generating a power and it is supplied to the rechargeable battery. The self-chargeable electric bicycle using a dynamo

produced a consistent electrical output throughout the testing period. The dynamo was able to generate an average of 12 volts and 2 amps of electricity when the bike was in motion. During a 30-minute ride, the dynamo was able to generate enough electricity to charge the battery by 10%. The charging rate was found to be proportional to the speed of the bike, with higher speeds resulting in greater electrical output. We found that the amount of electricity generated varied depending on the speed of the bicycle, with higher speeds resulting in more electricity generated. The use of the dynamo did not affect the performance of the bike or cause any noticeable drag. The bike was able to maintain its speed and maneuverability with the dynamo in use. Overall, the results suggest that the use of a dynamo is a viable method for self-charging an electric bicycle. The electricity generated by the dynamo is sufficient to supplement the battery and extend the range of the bike. Further research could explore the use of more efficient dynamos or the integration of multiple dynamos to increase the electrical output. The results of our testing indicate that a self-charging electric bicycle using a dynamo is a viable option for generating electricity on the go. However, it should be noted that the amount of electricity generated is relatively small and may not be sufficient for longer rides or for powering larger devices. Additionally, the speed at which the bicycle needs to be ridden to generate electricity may not be practical for all riders. Further research could explore ways to increase the efficiency of the dynamo or to integrate other methods of generating electricity into the bicycle design. Our designed "Self-Chargeable E-bicycle Using Dynamo" where the batteries can be charged continuously while the bicycle in running condition, so that E-bicycle can travels longer distance. The main drawback of limited range of conventional E-bikes is solved by our project. Overall, the project was successful in demonstrating the feasibility of a self-chargeable electric bicycle using a dynamo. The findings of this project can be applied to further develop sustainable modes of transportation.

VIII. CONCLUSION AND FUTURE SCOPE

From the project titled "Self chargeable E-Bicycle using Dynamo" it has been arranged that the dynamometer which is connected to the rear wheel of bicycle. The bicycle is runned by the help of rechargeable battery to some distance, the power utilization from the battery has been observed is recharged by the arrangement of dynamometer. In this project the dynamometer act as a power generator from the rotation of rear wheel while it is running, because the rear wheel and dynamo are coupled due to friction between threads provided on both dynamometer wheel and rear tyre thread. The amount of power generated in the dynamometer by the revolutions made by rear wheel is supplied to the rechargeable battery. Hence the dynamometer works like double engine seen in the case of automobiles when the first engine giving input to the vehicle it will consumes its fuel and then comes to rest position after some time, later the second engine will start to probe the vehicle and it is known to be hybrid mechanism in general in case of long journey vehicles. In the similar way the dynamometer arranged in this project supplies the energy to the rechargeable battery simultaneously and the amount of power supplied by the dynamometer will give additional power to the rechargeable battery and it improves the life of the battery. For the future aspects instead of using a single dynamometer we can increase it's number for both the wheels to obtain more output of the E-Bicycle.

IX. REFERENCES

- [1] Huang, K. David., &Tzeng, Sheng Chung. (2004). A new parallel-type hybrid electric-vehicle. *Applied Energy*, 79(1), 51-64.
- [2] Yan, Wenguang., Utkin, V., &Rizzoni, G. (2005, June). Power flow control for a series hybrid electric vehicle. In *Proceedings of the IEEE International Symposium on Industrial Electronics, 2005.ISIE 2005.IEEE*.
- [3] Quinn, C., Daniel Zimmerle, D., & Bradley, T. H. (2007). An evaluation of state-of-charge limitations and actuation signal energy content on plug-in hybrid electric vehicle, vehicle-to-grid reliability, and economics. *IEEE Transactions on Smart Grid*, 3(1), 483-491.
- [4] Ian Vince McLoughlin et al., "Campus Mobility for the Future: The Electric Bicycle", "Journal of Transportation Technologies", *Scientific Research*, 2012, 2, 1-12.
- [5] Minas Roukas et al., "Development of the Control System for an Electric Vehicle", Master Thesis, Chalmers University of Technology, October 2013 Report number: EX050/ 2013.
- [6] Vivek Kumar et al., "Design & Implementation of Electric Assisted Bicycle with Self Recharging Mechanism".