

SOLAR BASED DOMESTIC REFRIGERATION SYSTEM USING PELTIER MODULE

Prof. A. M. Halmare^{*1}, Santosh Sawale^{*2}, Chandrakant Kapur^{*3}, Arshad Shaikh^{*4}

^{*1}Professor, Department Of Electrical Engineering, Karmaveer Dadasaheb Kannamwar Engineering Collage, RTMNU University, Nagpur, Maharashtra, India.

^{*2,3,4}Department Of Electrical Engineering, Karmaveer Dadasaheb Kannamwar Engineering Collage, RTMNU University, Nagpur, Maharashtra, India.

ABSTRACT

Now a day, we have many difficulty such as many energy crisis and environment degradation due to the rising CO₂ emission and ozone layer depletion has become the primarily examine to both developed and developing countries. Our project make use of the solar energy for its operation. Solar refrigeration using Peltier module is joining be one of the most cost effective, dirt-free and environment friendly systems. Cooling can be done in a single system which is possible due to the peltier effect. This paper does not need any kind of refrigerant and mechanical gadget like compressor, prime mover, etc for its working. The main purpose by this method is to provide refrigeration system to the remote areas where power supply is not possible.

Solar-powered Refrigeration system that eliminates burning crude oil and reliance on an electric grid .This study mainly focus on Direct current (DC) vapour compression coolings system, connected to a solar photovoltaic cell based compressor less Refrigerator via novel electronic controls .This environmental friendly system is ideally for use in domestic purpose as well as business purpose. The plan of solar powered refrigerator required minimum temaperatures upto five degree celcius.

KEYWORD: Refrigeration, Peltier effect, Battery, SolarPanel, charge controller, 16X2 LCD display.

I. INTRODUCTION

Even though the PV power aqua ammonia system has been commercialized, aqua ammonia system needs attention of the analyst after all they are occupying the 91% market of the family utilization. The chilling process means removing heat from a particular surrounded space to make its temperature lower than the nearby temperature (0-6). For running these systems, the electricity is consumed from the grid. In this proposed research, a practicality study has been done on the aqua ammonia chilling system operated on solar power. The load requirement of the family refrigerator having 25W running for 4 hours a day has been calculated. The title is to provide a device that can do the same purpose without polluting the nature and to reduce the production of the CO₂, SO₂ because it affects our nature refusal.

The high o/p of CO₂, SO₂ has to the following impact on the situation of climate change. This study was a part of the modern intelligence automation that make use of the solar energy. It blueprint and develops a preliminary unit that was illustrating the practicality and economic feasible of solar energy for the plan purposes. Increasing the going average earth rising air and average sea temperatures can be defined as global warming. It is caused by raising the attentiveness of the greenhouse gases that generated by human being behaviour. It observed that the air temperatures and sea have increased by about 0.9°C which requires to be solved . Due to the production of electricity, the release of toxic waste has increased and amounts of ultraviolet B rays to spread among the earth which causes skin cancer in humans and harm animals. Most of the semiconductor materials, back coefficient, electric and thermal conductivity is strongly temperature dependence. The present transient model is utilized to differentiate the dynamic temperature varieties at both cold and hot ends with constant and variable material properties. The applied electric currents with low, medium and high connected with different cooling loads are assumed as a working condition. The findings prove that, at low current, the steady property show created by this work can predict precisely the dynamic characteristics, moreover as the electric current increases

the temperature dependence of properties have an increasingly notable impact on the active temperature varieties, particularly for high cooling loads.

II. METHODOLOGY

Below figure show the experimental block diagram of the solar peltier refrigerator which function as the refrigerator system in many feature:

A. Peltier Module:

The effect of Peltier is a key idea in this study. The thermoelectric effect is a direct interchange of temperature dissimilarity to electric voltage and vice-versa. A thermoelectric gadget make a voltage once there is an change temperature on each side. The heat will remove from one of the alloy and carry to the other after all the electrical current applied across the intersection of two dissimilar metals. Thermoelectric refrigerant operate by Peltier effect. However, the device has two sides when a DC electric current passes above the Peltier , it cause heat from each side which one side gets cooler while the other hotter . The hot side is devoted to the heatsink which residue at ambience temperature. On the other hand, the freezing runs under the room temperature.

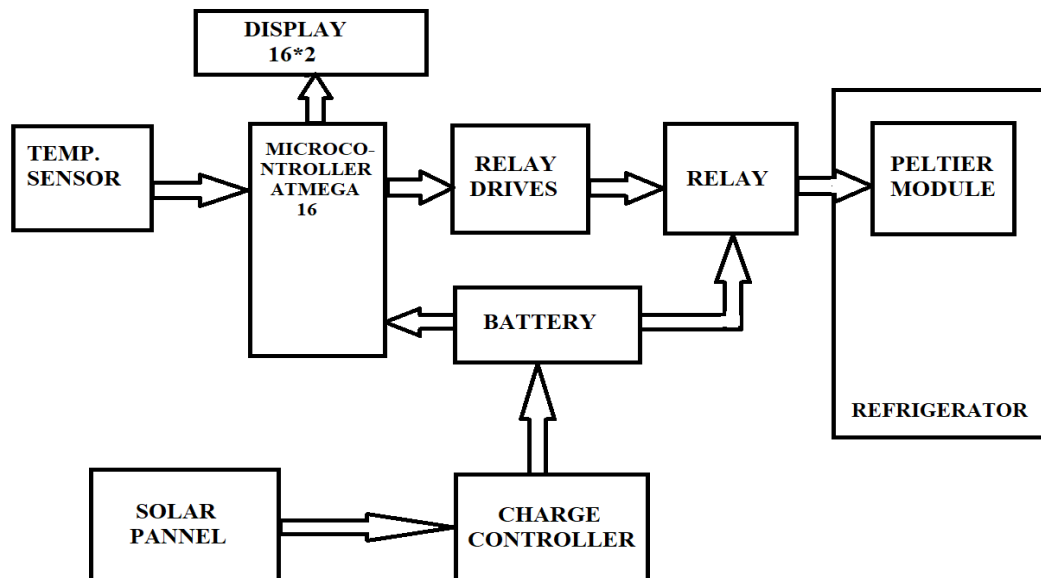

Fig-1: Block Diagram Solar Based Refrigeration System

B. Temperature Controller and Solar Panel:

The temperature controller is analytic and it get the input from a temperature sensor and the output attached to control component such as a heater or fan. The solar panel is a photovoltaic cell that change the light energy into electrical energy. The solar panel output voltage depended on the quantity of light falling on the panel and used as a analytic source of energy in this examine. The power of the solar panel, output voltage and current, 25 W, 12 V DC and 12 A respectively. The solar panels used as a individual process to change the photons to electrons to make a current by generating a particular type of cell called as a photovoltaic cell. The photovoltaic cells created of semi-conductive substance such as silicon, and it gets the light from the sun .When happen, the photons in the sunlight hit some of the electrons in the photovoltaic cells material which allow to run in an electrical current. There is an electric pasture within each cell which is used to efficient this flow of electrons in a specific direction. It can be used as a power gadget while these electrons come through a alloy contact placed on the PV cell.

C. Battery with Built-in Inverter and CPU Cooler:

The battery with construct-in inverter voltage and current used in this examine has 12 V and 12 A. The output for four ports is 12V DC with 14 V Converter. New battery based inverters supply sufficient DC to AC power change. Attached the inverter/charger to an AC power source free whole fresh field of application pliability. The generators have been the nearly all common backup source for off-grid and intensified the system tentative and pliability and used in high power , infrequent loads. Through a stretch of cloudy weather, it can simultaneously power loads and abet in recharging the batteries. The generator can reduce the price of a PV-based system by allowing it to size for average annual insolation as an alternative of low winter daylight hour. If the batteries or inverter fail, a generator can give out as a stand-alone backup to the inverter system. The CPU cooler has analytically ventilated the heat caused from the components and actively cools the processor by bringing in the colder air ahead the heat harms the parts. It is the nearly all economical and practical way to cool through out the Peltier and scured it from overheating. The CPU fan is analytically required to ventilate the heat that generated from the parts and actively cools the Peltier by bringing in the more cooling air before the heat harms the Peltier. Cooling the fans for the Peltier are existing in dissimilar sizes and usually sold with an aluminum or copper heatsink fan. The CPU cooling fans are devoted to directly to the Peltier and function along with an aluminum heatsink fan to cool down the Peltier. The fan is attached to the fin-like construction and intensify the convey of hot air by towing the hot air from the electrical heat that generated by the element and pushing in the more cooling air between the aluminum fins which keep the processor cool.

III. CONCLUSION

The following concluding records have been made based on the experimental examine shows below:

1. The lowest temperature arrived at 10°C for the cooling while the highest temperature was obtained at 60°C for heating.
2. Using solar based refrigerator as an alternative of using compressor operated refrigerator has many profit such as saving the environment, cost, and health.
3. The thermoelectric effect gadget used as heat pumps, cooler, thermal energy sensors.
4. The crucial challenge overlook in Thermoelectric cooling is the lower coefficient of performance, exclusively in large capacity systems.
5. Examine different thermoelectric substance are essential to intensify the thermoelectric cooler coefficient of performance.

IV. REFERENCES

- [1] Jai kishor Vermaa , Raja Sekhar Dondapati, “Techno-economic sizing analysis of solar PV system for Domestic Refrigerators”
- [2] Hazim Moria, Munner Ahmed, Ashraf Alghanmi, Taib Iskandar Mohamad, Yusli Yaakob, “Experimental Study of Solar Based Refrigerator Using Thermoelectric Effect” .
- [3] Uttam Kumar Chaudhary, Adarsh Patel, Deepak Arya, Deepanshu Gautam, Prasoon Chaudhary, “Solar Refrigeration Using Peltier Moodule”.
- [4] Abhishek sharma, Dr.Alka Bani Agrawal, Dr. Nitin Shrivastava, “ Solar Energy based Refrigeration System using Peltier Device”.
- [5] D. K. C. MacDonald, “Thermoelectricity: An Introduction to the principles”.
- [6] H. Julian Goldsmid, “The Physics of Thermoelectric Energy Conversion”.
- [7] Digambar Kashid, “Thermo-electric Power Generation Using Exhaust Heat Energy: Generation of electrical energy with the help of TEG using exhaust heat energy from I.C. engine”.